

PRODUCT BULLETIN

Series V46
Pressure Actuated Modulating Valves

Introduction

These pressure actuated modulating valves control the quantity of water to a condenser by directly sensing pressure changes in a refrigerant circuit. The valves can be used in non-corrosive refrigerant systems. Ammonia power elements and valves designed for salt-water applications are available. The valves have a quick opening characteristic and open on pressure increase (direct acting). Reverse acting (close on pressure increase) is possible.



Series V46
Pressure Actuated Water Regulating Valve

Feature and Benefits

<input type="checkbox"/> Pressure balanced valve design	Setpoint is independent from water inlet pressure
<input type="checkbox"/> High refrigerant pressure resistant bellows	Refrigeration pressure may increase up to 28 bar without bellow damage
<input type="checkbox"/> Pressure actuated	Direct and fast response to pressure variations
<input type="checkbox"/> 3/8, 1/2, 3/4" are angled body type valves with high Kv value	Small dimensions with high flow capacity
<input type="checkbox"/> 3/8" up to 2" pressure valves "all range" types	Reduces stock. One valve for all non-corrosive refrigerants
<input type="checkbox"/> Quick opening valve characteristics	Fast response to pressure increase
<input type="checkbox"/> No close fitting or sliding parts in water passages	No hysteresis increase or stuck valve caused by contamination
<input type="checkbox"/> Easy to disassemble. All parts can be replaced	Valve can easily be repaired "in line". Valve piece parts are available "world-wide"
<input type="checkbox"/> Special bronze bodies and monel parts	Used for sea water applications
<input type="checkbox"/> Power elements with stainless steel bellows available	For use on ammonia filled equipment
<input type="checkbox"/> Wide range of pressure connection styles	Possibility to meet the legislation in your country
<input type="checkbox"/> Nickel plated seats available for 3/8, 1/2, and 3/4" valves	High resistant against erosion/ corrosion and cavitation
<input type="checkbox"/> Direct/reverse action	Control action can be (factory) changed

Note

All series V46 water regulating valves are designed for use only as operating devices. Where system closure, improper flow or loss of pressure due to valve failure can result in personal injury and/or loss of property, a separate pressure relief or safety shut off valve, as applicable, must be added by the user.

Description

A pressure-balanced design employing rubber sealing diaphragms correctly proportioned to the valve port area, balances valve against both gradual and sudden water pressure changes, and seals water away from range spring, guides and sliding parts so these are not submerged in water where they would be subject to sedimentation and corrosion. Only five metal parts, made of corrosion resistant material, come in contact with the water. These are the valve disc holder, the disc stud, the valve seat, the valve stem, and the body.

Adjustments

The pressure at which the valve starts to open (= opening point) can be adjusted by the adjusting screw located at the top of the range spring housing. Valves may be adjusted with standard service valve wrenches or screwdrivers. (Valves are not factory set at a certain value.)

Manual flushing

Valves may be manually flushed by lifting the lower spring guide with screwdrivers at two sides of the pressure plate to open valve. This does not affect valve adjustment.

Valve size selection

The valve size is determined by three data:

- The required maximum flow (quantity of liquid = Q) that must pass the valve (in m³/h).
- The maximum allowed pressure drop (= ΔP) across the valve (in bar).
- The head pressure rise (= HPR) which is the difference between the pressure where the valve starts to open and the condenser operating pressure.

Note

At a certain pressure the valve starts to open. If the pressure decreases, the valve will close again at a \square 0,5 bar lower pressure than the pressure where the valve starts to open.

Note

If the compressor operates in a high ambient temperature, the refrigerant pressure may at times remain high enough to cause the valve to partly open when the compressor is idle. In such conditions the valve opening point should be raised just enough to cause the valve to close during compressor standby periods. Take this into account when the head pressure rise (HPR) is calculated.

The valve size can be selected by the use of:

- the diagram (see page 3 and 4).
- K_V factors and calculation formulae (see page 3). This can only be used when the allowed head pressure rise is 3 bar or higher. At lower head pressure rises the diagram has to be used.

Valve size selection by the use of the diagram page 4

Q: The quantity of water (m³/h) is indicated on the left side of the upper diagram (= scale A).

□ P: The curves for the pressure drop across the valve are indicated in the lower diagram (0,1 up to 4 bar, see scale C).

HPR: The head pressure rise above the valve opening point is indicated at the left side of the lower diagram (max. 4 bar, see scale B).

Note

There are two vertical head pressure rise scales. The left side for range 5/18 bar valves and the right side for high ranges 5/23 and 10/23 bar valves.

Valve size: The valve size can be read from the right side of the upper diagram.

Valve size selection example:

Q = 6,5 m³/h
HPR = 2,7 bar
□ P = 0,5 bar

- Draw a horizontal line through the 6,5 m³/h point of scale A (see A).
- Draw a horizontal line through the 2,7 bar of scale B (see B). The intersection of this horizontal line with the delta P curve of 0,5 bar is used to draw a vertical line from this intersection point up to the horizontal line in scale A (see C).
- The intersection point of this vertical line with the horizontal line in scale A indicates the valve size. If the point falls on a size curve, this is the valve size needed. If it is between two sizes always take the largest valve size. In this example it is between size 1¹/₄" and 1¹/₂".
The selected valve is 1¹/₂".

Of course the same diagram can be used to read the pressure drop across a valve or to find the maximum capacity of a valve.

E.g. Pressure drop.

Q needed is 6 m³/h.
HPR is 2,5 bar.
The valve size available is 3/4".
What will be the pressure drop?

Solution:

- Draw a horizontal line through 6 m³/h (scale A) and determine the intersection of this line with the 3/4" valve curve.
- Draw a vertical line from this intersection point to the 2,5 bar HPR line.
- The found part is between the 2 and 3 bar pressure drop curves. Interpolate the point which gives 2,3 bar.
If this is acceptable the valve can be used.

E.g. Maximum flow.

Valve size is 1"
HPR = 3 bar
Maximum □ P = 2 bar
What is maximum Q?

Solution:

- Draw a horizontal line at 3 bar HPR (scale B) till intersection with 2 bar delta P curve.
- Draw a vertical line from this intersection point to the 1" valve curve.
- Draw from this point a horizontal line to the water flow scale A.
You find 9 m³/h.

Valve size selection by the use of the K_v factors and calculation formulae

For water:

The following K_v values can be used:

$$K_v = \frac{Q}{\sqrt{\Delta p}}$$

$$\Delta P = \left(\frac{Q}{K_v}\right)^2$$

$$Q = K_v \cdot \sqrt{\Delta p}$$

Valve size	K _v value
3/8"	1.8
1/2"	2.7
3/4"	4.5
1"	6.5
1 1/4"	9
1 1/2"	10.5
2"	18 (low range)
2"	17 (high range)
2 1/2"	22 (low range)
2 1/2"	20 (high range)

Q = quantity of liquid (in m³/h)
Δ P = pressure drop across valve (in bar)
K_v = valve flow coefficient

The K_v factor is the quantity of 20°C water that will pass through the valve at one bar pressure drop and a valve opening which belongs by 3 bar head pressure rise (HPR) above the valve opening point.

Diagram for selecting the valve size corresponding with information on page 3

Note: Use dotted curves for high range 2" and 2½" valves

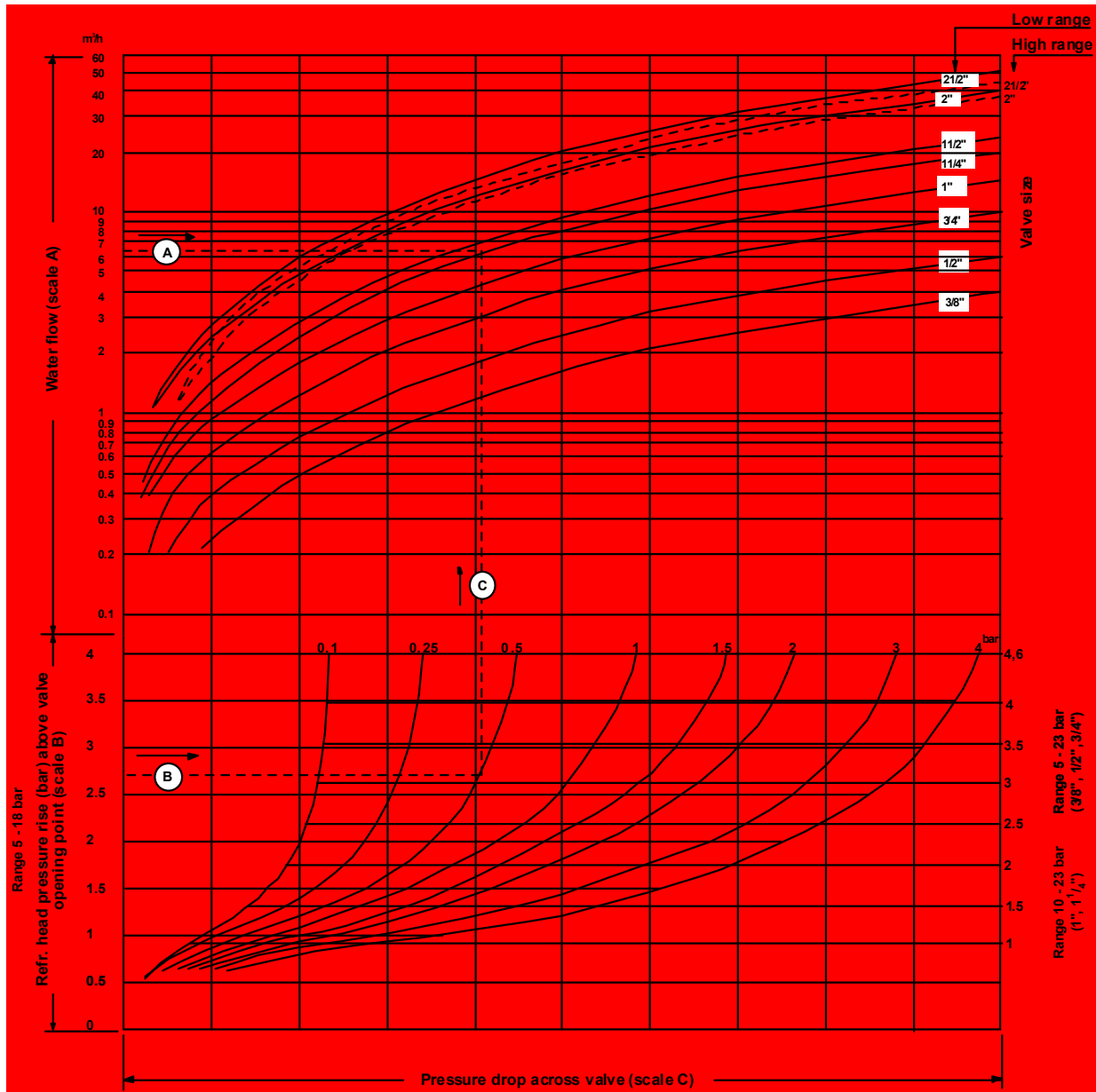

Note: 1 dm³/s = 3.6 m³/h = 15.8 U.S. gal./min. = 13.2 U.K. gal./min.
1 bar = 100 kPa = 0.1 MPa □ 1.02 kp/cm² = 1.02 at □ 14.5 psi.

Fig. 1

Ammonia (NH₃) applications

For all larger valve types an ammonia element is available. These elements have style 15 pressure connection and consist of a stainless steel bellow in a steel cup (coated). The existing element can be replaced by this ammonia element. The pressure range does not change. For the high range valves (V46AS/AT/BS/BT) the spring inside the power element has to be placed in the ammonia element. If low pressure is needed this spring can be removed. For low quantities you have to order the selected valve and separate ammonia replacement power element (see valve type selection table). For quantity orders a special valve type can be set up. Then please contact the JC sales office in your region.

Repair and replacement

Diaphragm kits can be ordered for all valves. Also the complete power element can be replaced. For a total revision of the valve a renewal kit can be ordered.

For type numbers of replacement power elements, renewal kits and diaphragm kits see valve selection table.

If a replacement is ordered a "repair parts and service instruction" sheet will be included in which a step by step description is given to disassemble/assemble the valve.

Renewal KITS

Each KIT contains parts as indicated in the table below. The complete KIT must be ordered that contains part required.		Disc cup	Valve disc	Plunger disc	Seat guide post	Disc stud	Valve stem	Valve disc holder	Extention sleeve	Valve seat	Diaphragms	Gasket	Valve seat wrench	Screw	Seal ring
Valve type:	KIT number:														
V46AA	STT002N600R	1	1	-	1	1	1	-	-	1	4	1	1	-	1
V46AB	STT003N600R	1	1	-	1	1	1	-	-	1	4	1	1	-	1
V46AC	STT004N600R	1	1	-	1	1	1	-	-	1	4	1	1	-	1
V46AD	STT17A609R	1	1	-	1	1	1	-	-	1	5	1	1	-	1
V46AE	STT17A610R	1	1	-	1	1	1	-	-	1	5	1	1	-	1
V46AR	STT17A610R	1	1	-	1	1	1	-	-	1	5	1	1	-	1
V46AS	STT18A600R	-	1	1	-	-	-	1	1	1	5	1	-	1	1
V46AT	STT18A601R	-	1	1	-	-	-	1	1	1	5	1	-	1	1
V46BA	STT14A601R	1	1	-	1	1	1	-	-	1	4	-	1	-	-
V46BB	STT15A603R	1	1	-	1	1	1	-	-	1	4	-	1	-	-
V46BC	STT17A613R	1	1	-	1	1	1	-	-	1	4	-	1	-	-
V46BD	STT17A611R	1	1	-	1	1	1	-	-	1	5	-	1	-	-
V46BE	STT17A612R	1	1	-	1	1	1	-	-	1	5	-	1	-	-
V46BR	STT17A612R	1	1	-	1	1	1	-	-	1	5	-	1	-	-
V46BS	STT18A602R	-	1	1	-	-	-	1	1	1	5	-	-	1	-
V46BT	STT18A602R	-	1	1	-	-	-	1	1	1	5	-	-	1	-

Pressure connections

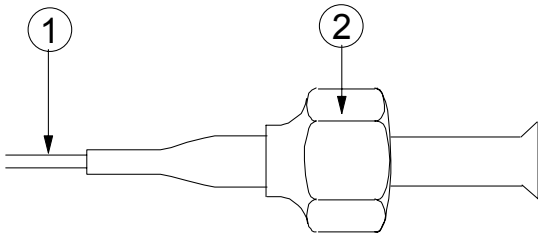

Fig. 2
Style 13 (excl. valve depressor)

- 1. 75 cm capillary
- 2. 7/16-20 UNF flare nut

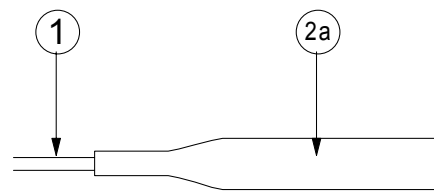

Fig. 3
Style 34

- 1. 75 cm capillary
- 2. 1/4" tube for braze connection

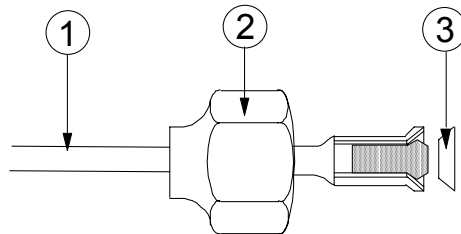

Fig. 4
Style 50 (incl. valve depressor mounted into machined flare)

- 1. 75 cm capillary.
- 2. 7/16 - 20 UNF flare nut.
- 3. copper sealring

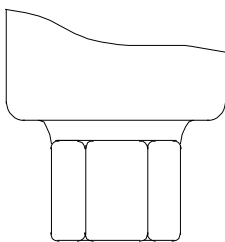

Fig. 5
Style 15
1/4-18NPT (female)

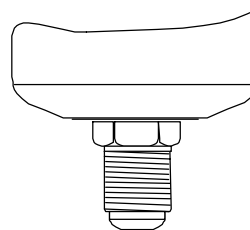

Fig. 6
Style 5
7/16-20 UNF

Dimensions (mm)

For valve type see specifications page 11

Angled type

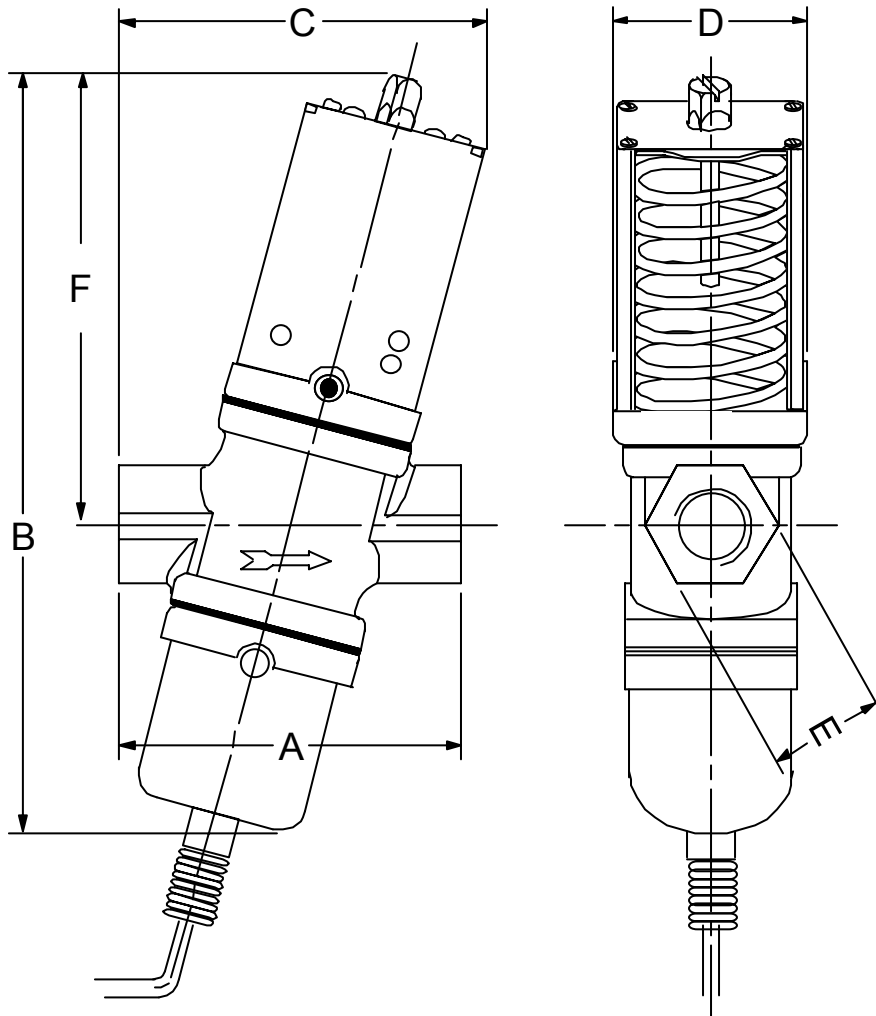

Fig. 7

Commercial Types

Valve type	Valve size	Dimensions in mm					
		A	B	C	D	E	F
V46AA	3/8"	69	153	66	43	18	89
V46AB	1/2"	80	170	86	51	27	100
V46AC	3/4"	91	183	95	55	36	110

Dimensions (mm)

For valve type see specifications page 11

Straight type

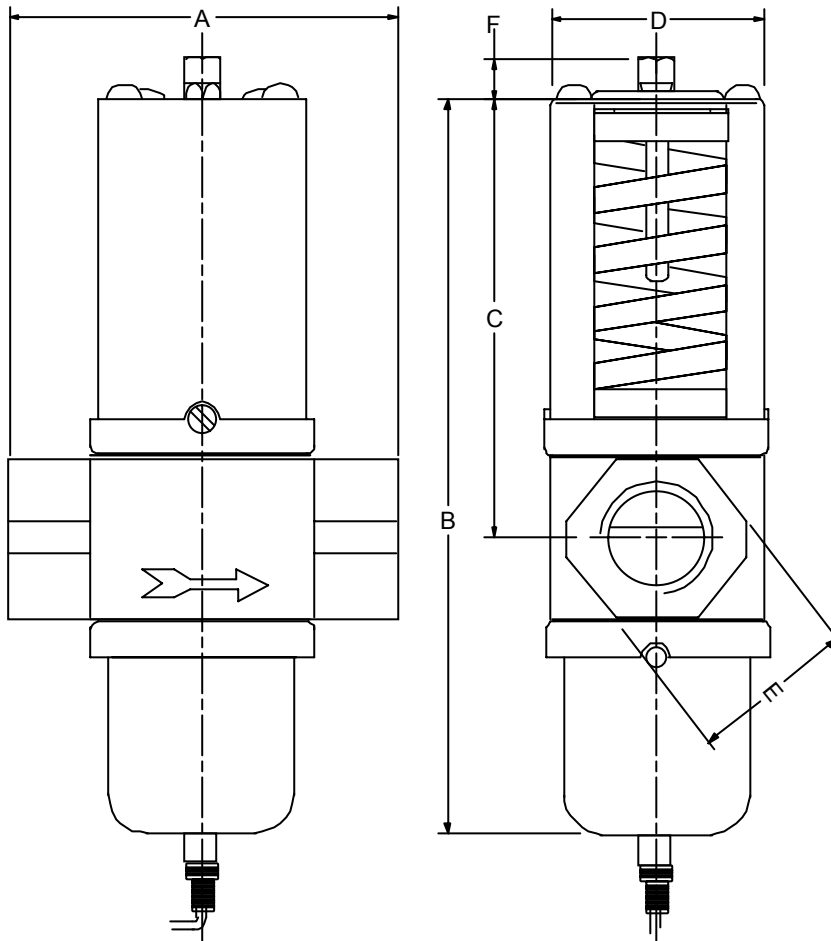

Fig. 8

Commercial Types

Valve type	Valve size	Dimensions in mm.					
		A	B	C	D	E	F
V46AD	1"	124	233	139	72	50	13
V46AE	1 1/4"	125	243	145	72	58	13

Sea-water Types

V46BA	3/8"	68	161	80	42	32	10
V46BB	1/2"	79	165	86	52	29	10
V46BC	3/4"	86	175	96	55	35	10
V46BD	1"	124	246	139	71	52	13
V46BE	1 1/4"	124	254	144	71	62	13

Dimensions (mm)

For valve type see specifications page 11

Flange type

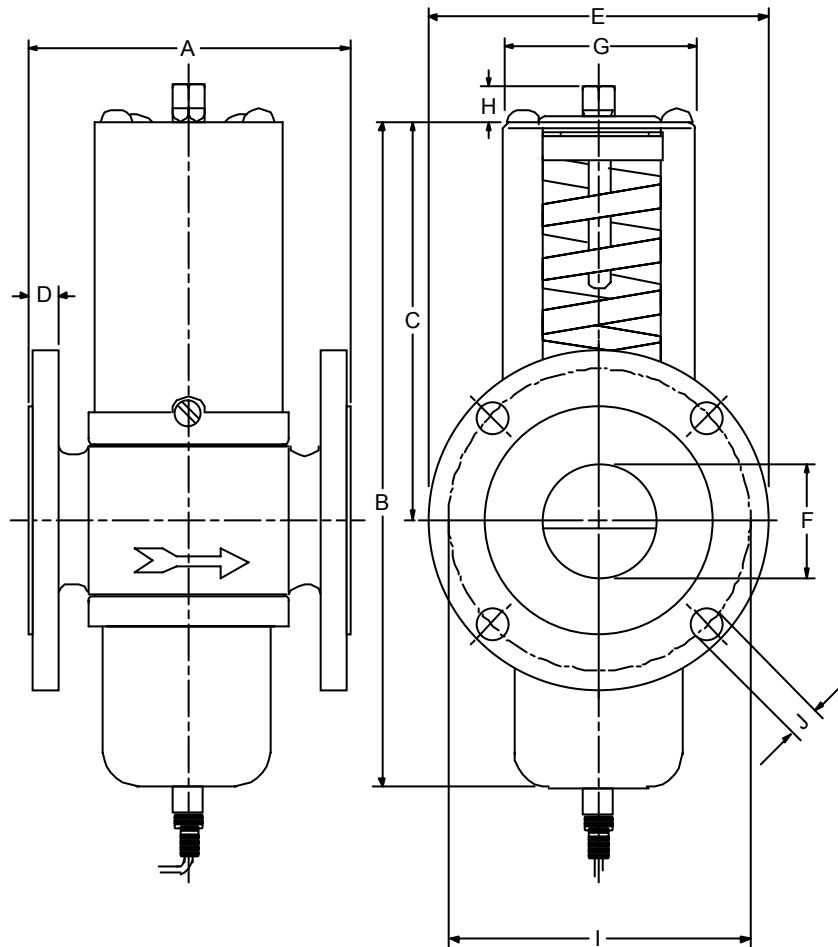

Fig. 9

Commercial Types

Valve type	Valve size	Dimensions in mm.									
		A	B	C	D	E	F	G	H	I	J
V46AR	1 1/2"	137	244	144	20	150	48	72	13	110	18
V46AS	2"	168	304	164	20	165	57	95	15	125	18
V46AT	1 1/2"	172	304	164	21	185	70	95	15	145	18

Sea-water Types

V46BR	1 1/2"	136	235	141	14	150	46	71	13	110	18
V46BS	2"	162	292	160	17	165	56	95	15	125	18
V46BT	1 1/2"	172	293	160	17	185	68	95	15	145	18

Valve selection table

Commercial types

Item	Size inch	Range bar	Refrig. connec. style	Capil. length m	Connection thread/flange	Replacements			Ammonia element type	Weight single pack kg.	Qty per box	Weight per box kg.
						power element	renewal kit	diaphragm kit				
V46AA-9300	3/8	5/23	5	-	ISO 228 - G ³ / ₈	-	STT002N600R	KIT016N600 (100)	-	0.9	24	22.0
V46AA-9301	3/8	5/23	5	-	ISO 228 - G ³ / ₈	-	STT002N600R	KIT016N600 (100)	-	0.9	24	22.0
V46AA-9510	3/8	5/23	50	0.75	ISO 228 - G ³ / ₈	-	STT002N600R	KIT016N600 (100)	-	0.9	24	22.0
V46AA-9511	3/8	5/23	51	1.2	ISO 228 - G ³ / ₈	-	STT002N600R	KIT016N600 (100)	-	0.9	24	22.0
V46AA-9600	3/8	5/18	13	0.75	ISO 228 - G ³ / ₈	246-821R	STT002N600R	KIT016N600 (100)	-	0.9	24	22.0
V46AA-9602*	3/8	5/18	13	1.00	ISO 228 - G ³ / ₈	-	STT002N600R	KIT016N600 (100)	-	0.9	24	22.0
V46AA-9606*	3/8	5/23	13	0.75	ISO 228 - G ³ / ₈	246-821R	STT002N600R	KIT016N600 (100)	-	0.9	24	22.0
V46AA-9620	= Bulkpack V46AA-9600											
V46AA-9950*	3/8	5/18	34	0.75	ISO 228 - G ³ / ₈	-	STT002N600R	KIT016N600 (100)	-	0.9	24	22.0
V46AB-9300	1/2	5/23	5	-	ISO 228 - G ¹ / ₂	-	STT003N600R	KIT016N601 (100)	-	1.3	18	24.0
V46AB-9510	1/2	5/23	50	0.75	ISO 228 - G ¹ / ₂	-	STT003N600R	KIT016N601 (100)	-	1.3	18	24.0
V46AB-9600	1/2	5/18	13	0.75	ISO 228 - G ¹ / ₂	246-824R	STT003N600R	KIT016N601 (100)	-	1.3	18	24.0
V46AB-9605*	1/2	5/23	13	0.75	ISO 228 - G ¹ / ₂	246-824R	STT003N600R	KIT016N601 (100)	-	1.3	18	24.0
V46AB-9950	1/2	5/18	34	0.75	ISO 228 - G ¹ / ₂	-	STT003N600R	KIT016N601 (100)	-	1.3	18	24.0
V46AB-9951*	1/2	5/23	34	0.75	ISO 228 - G ¹ / ₂	-	STT003N600R	KIT016N601 (100)	-	1.3	18	24.0
V46AC-9300	3/4	5/23	5	0.75	ISO 228 - G ³ / ₄	-	STT004N600R	KIT016N602 (100)	-	1.7	14	25.5
V46AC-9510	3/4	5/23	50	0.75	ISO 228 - G ³ / ₄	-	STT004N600R	KIT016N602 (100)	-	1.7	14	25.5
V46AC-9600	3/4	5/18	13	0.75	ISO 228 - G ³ / ₄	246-825R	STT004N600R	KIT016N602 (100)	-	1.7	14	25.5
V46AC-9605*	3/4	5/23	13	0.75	ISO 228 - G ³ / ₄	246-825R	STT004N600R	KIT016N602 (100)	-	1.7	14	25.5
V46AC-9606	3/4	5/18	13	1.20	ISO 228 - G ³ / ₄	-	STT004N600R	KIT016N602 (100)	-	1.7	14	25.5
V46AC-9951	3/4	5/18	34	0.75	ISO 228 - G ³ / ₄	-	STT004N600R	KIT016N602 (100)	-	1.7	14	25.5
V46AD-9300	1	5/18	5	-	ISO 7 - Rc 1	-	STT17A609R	KIT016N603 (50)	246-667R	3.5	1	3.5
V46AD-9510	1	5/18	50	0.75	ISO 7 - Rc 1	-	STT17A609R	KIT016N603 (50)	246-667R	3.5	1	3.5
V46AD-9511	1	10/23	50	0.75	ISO 7 - Rc 1	-	STT17A609R	KIT016N603 (50)	246-667R	3.5	1	3.5
V46AD-9600	1	5/18	13	0.75	ISO 7 - Rc 1	246-925R	STT17A609R	KIT016N603 (50)	246-667R	3.5	1	3.5
V46AE-9300	1 1/4	5/18	5	-	ISO 7 - Rc 1 1/4	-	STT17A610R	KIT016N603 (50)	246-667R	3.8	1	3.8
V46AE-9510	1 1/4	5/18	50	0.75	ISO 7 - Rc 1 1/4	-	STT17A610R	KIT016N603 (50)	246-667R	3.8	1	3.8
V46AE-9512	1 1/4	10/23	50	0.75	ISO 7 - Rc 1 1/4	-	STT17A610R	KIT016N603 (50)	246-667R	4.0	1	3.8
V46AE-9513	1 1/4	10/23	50	1.50	ISO 7 - Rc 1 1/4	-	STT17A610R	KIT016N603 (50)	246-667R	4.0	1	3.8
V46AE-9600	1 1/4	5/18	13	0.75	ISO 7 - Rc 1 1/4	246-925R	STT17A610R	KIT016N603 (50)	246-667R	3.8	1	3.8
V46AE-9700	1 1/4	7/14	15	-	ISO 7 - Rc 1 1/4	246-667R	STT17A610R	KIT016N603 (50)	-	3.8	1	3.8
V46AE-9950	1 1/4	5/18	34	1.30	ISO 7 - Rc 1 1/4	246-667R	STT17A610R	KIT016N603 (50)	-	3.8	1	3.8
V46AR-9300	1 1/2	5/18	5	-	Flange 1 1/2 DIN2533	-	STT17A610R	KIT016N603 (50)	246-667R	7.5	1	7.5
V46AR-9600	1 1/2	5/18	13	0.75	Flange 1 1/2 DIN2533	246-925R	STT17A610R	KIT016N603 (50)	246-667R	7.5	1	7.5
V46AR-9700	1 1/2	7/14	15	-	Flange 1 1/2 DIN2533	246-667R	STT17A610R	KIT016N603 (50)	-	7.5	1	7.5
V46AS-9300	2	5/11.5	5	-	Flange 2 DIN2533	246-671R	STT18A600R	KIT016N604 (25)	246-781R	13.0	1	13.0
V46AS-9301	2	11/18	5	-	Flange 2 DIN2533	246-758R	STT18A600R	KIT016N604 (25)	246-781R	13.0	1	13.0
V46AS-9700	2	7/14	15	-	Flange 2 DIN2533	246-781R	STT18A600R	KIT016N604 (25)	-	13.0	1	13.0
V46AT-9300	2 1/2	5/11.5	5	-	Flange 2 1/2 DIN2533	246-671R	STT18A601R	KIT016N604 (25)	246-781R	14.0	1	14.0
V46AT-9301	2 1/2	11/18	5	-	Flange 2 1/2 DIN2533	246-758R	STT18A601R	KIT016N604 (25)	246-781R	14.0	1	14.0
V46AT-9700	2 1/2	7/14	15	-	Flange 2 1/2 DIN2533	246-781R	STT18A601R	KIT016N604 (25)	-	14.0	1	14.0

* nickel plated seat

Sea-water types

Item	Size inch	Range bar	Refrig. connec. style	Capil. length m	Connection thread/flange	Replacements			Ammonia element type	Weight single pack kg.	Qty per box	Weight per box kg.
						power element	renewal kit	diaphragm kit				
V46BA-9510	3/8	5/18	50	0.75	ISO 228 - G ³ / ₈	-	STT14A601R	KIT016N600 (100)	-	0.8	24	20.0
V46BA-9600	3/8	5/18	13	0.75	ISO 228 - G ³ / ₈	246-723R	STT14A601R	KIT016N600 (100)	-	0.8	24	20.0
V46BB-9510	1/2	5/18	50	0.75	ISO 228 - G ¹ / ₂	-	STT15A603R	KIT016N601 (100)	-	1.3	18	24.0
V46BB-9600	1/2	5/18	13	0.75	ISO 228 - G ¹ / ₂	246-724R	STT15A603R	KIT016N601 (100)	-	1.3	18	24.0
V46BC-9510	3/4	5/18	50	0.75	ISO 228 - G ³ / ₄	-	STT17A613R	KIT016N602 (100)	-	1.7	14	25.0
V46BC-9511	3/4	5/23	50	1.40	ISO 228 - G ³ / ₄	-	STT17A613R	KIT016N602 (100)	-	1.7	14	25.0
V46BC-9600	3/4	5/18	13	0.75	ISO 228 - G ³ / ₄	246-752R	STT17A613R	KIT016N602 (100)	-	1.7	14	25.0
V46BC-9601	3/4	5/18	13	1.20	ISO 228 - G ³ / ₄	-	STT17A613R	KIT016N602 (100)	-	1.7	14	25.0
V46BD-9510	1	5/18	50	0.75	ISO 228 - G1	-	STT17A611R	KIT016N603 (50)	246-667R	4.0	1	4.0
V46BD-9600	1	5/18	13	0.75	ISO 228 - G1	246-755R	STT17A611R	KIT016N603 (50)	246-667R	4.0	1	4.0
V46BD-9601	1	5/18	13	1.20	ISO 228 - G1	-	STT17A611R	KIT016N603 (50)	246-667R	4.0	1	4.0
V46BE-9510	1 1/4	5/18	50	0.75	ISO 228 - G1 1/4	-	STT17A612R	KIT016N603 (50)	246-667R	4.5	1	4.5
V46BE-9511	1 1/4	10/23	50	1.50	ISO 228 - G1 1/4	-	STT17A612R	KIT016N603 (50)	246-667R	4.5	1	4.5
V46BE-9600	1 1/4	5/18	13	0.75	ISO 228 - G1 1/4	246-755R	STT17A612R	KIT016N603 (50)	246-667R	4.5	1	4.5
V46BE-9601	1 1/4	5/18	13	1.20	ISO 228 - G1 1/4	-	STT17A612R	KIT016N603 (50)	246-667R	4.5	1	4.5
V46BR-9510	1 1/2	5/18	50	0.75	Flange 1 1/2 DIN2533	-	STT17A612R	KIT016N603 (50)	246-667R	7.5	1	7.5
V46BR-9600	1 1/2	5/18	13	0.75	Flange 1 1/2 DIN2533	246-755R	STT17A612R	KIT016N603 (50)	246-667R	7.5	1	7.5
V46BS-9300	2	5/11.5	5	-	Flange 2 DIN2533	246-758R	STT18A602R	KIT016N604 (25)	246-781R	13.5	1	13.5
V46BS-9301	2	11/18	5	-	Flange 2 DIN2533	246-758R	STT18A602R	KIT016N604 (25)	246-781R	13.5	1	13.5
V46BT-9300	2 1/2	5/11.5	5	-	Flange 2 1/2 DIN2533	246-758R	STT18A602R	KIT016N604 (25)	246-781R	14.5	1	14.5
V46BT-9301	2 1/2	11/18	5	-	Flange 2 1/2 DIN2533	246-758R	STT18A602R	KIT016N604 (25)	246-781R	15.0	1	15.0
V46BT-9700	2 1/2	7/14	15	-	Flange 2 1/2 DIN2533	246-781R	STT18A602R	KIT016N604 (25)	246-781R	15.0	1	15.0

Specifications

Commercial

	Size	3/8" - 3/4"	1" - 1 1/4"	1 1/2"	2" - 2 1/2"	2" - 2 1/2"
Operating range (bar)		5-18 / 5-23	5-18 / 10-23	5-18	5-11,5	11-18
Max. refrig. overrun press. (bar)		28	28	28	28	28
Max. water supply press. (bar)		10	10	10	10	10
Max. water supply temp.		90 °C	90 °C	90 °C	90 °C	90 °C
Min. water supply temp.*		-20 °C	-20 °C	-20 °C	-20 °C	-20 °C
Valve hysteresis (bar)		~ 0,5	~ 0,5	~ 0,5	~ 0,5	~ 0,5
Valve body style	angled	x				
	straight		x	x	x	x
Pipe connection**	thread ISO 228	x				
	thread ISO 7 - Rc		x			
	flange DIN 2533			x	x	x
Material	body	hot forged brass	cast iron***	cast iron***	cast iron***	cast iron***
	disc stud/disc cup	brass	brass	brass	brass	brass
	seat	alum. bronze	alum. bronze	alum. bronze	alum. bronze	alum. bronze
	diaphragms	BUNA-N	BUNA-N	BUNA-N	BUNA-N	BUNA-N
	bellows	ph. bronze	ph. bronze	ph. bronze	tombac	monel
	stem/extension sleeve	brass	brass	brass	brass	monel
	disc	BUNA-N	BUNA-N	BUNA-N	BUNA-N	BUNA-N

Sea-water

	Size	3/8" - 3/4"	1" - 1 1/4"	1 1/2"	2" - 2 1/2"	2" - 2 1/2"
Operating range (bar)		5-18	5-18	5-18	5-11,5	11-18
Max. refrig. overrun press. (bar)		28	28	28	28	28
Max. water supply press. (bar)		10	10	10	10	10
Max. water supply temp.		90 °C	90 °C	90 °C	90 °C	90 °C
Min. water supply temp.*		-20 °C	-20 °C	-20 °C	-20 °C	-20 °C
Valve hysteresis (bar)		~ 0,5	~ 0,5	~ 0,5	~ 0,5	~ 0,5
Valve body style	straight	x	x	x	x	x
Pipe ** connection	thread ISO 228	x	x			
	flange DIN 2533			x	x	x
Material	body	bronze	bronze	bronze	bronze	bronze
	disc stud/disc cup	monel	monel	monel	monel	monel
	seat	monel	monel	monel	monel	monel
	diaphragms	BUNA-N	BUNA-N	BUNA-N	BUNA-N	BUNA-N
	bellows	ph. bronze	ph. bronze	ph. bronze	monel	monel
	stem/extension sleeve	monel	monel	monel	monel	monel
	disc	BUNA-N	BUNA-N	BUNA-N	BUNA-N	BUNA-N
Pressure connection style		See selection table.				
Capillary length		See selection table.				
Ammonia element style 15 press. connection		Stainless steel bellow in steel cup.				
Shipping weights		See valve selection table.				

* Care should be taken the valve does not freeze up.
 ** Thread ISO 7 - Rc = DIN2999-RC thread/ISO 228 = DIN259-Rp thread
 *** Cast iron bodies are executed with rust resisting finish

The performance specifications are nominal and conform to acceptable industry standards. For application at conditions beyond these specifications, consult the local Johnson Controls office. Johnson Controls, Inc. shall not be liable for damages resulting from misapplication or misuse of its products.



Johnson Controls International, Inc.
 Headquarters: Milwaukee, WI, USA
 European Headquarters: Brussels, Belgium
 European Factories: Lomagna (Italy), Leeuwarden (The Netherlands) and Essen (Germany)
 Branch Offices: Principal European Cities.
 This document is subject to change

www.johnsoncontrols.com
 Printed in Europe